

# Week One: Introduction

---

A SHORT INTRODUCTION TO HARDWARE,  
SOFTWARE, AND ALGORITHM DEVELOPMENT

# Outline

---

- In this chapter you will learn:
  - About computer hardware, software and programming
  - How to write and execute your first Python program
  - How to diagnose and fix programming errors
  - How to use pseudocode to describe an algorithm

# Our First Definition

---

## ***Algorithm:***

- An ***algorithm*** is a step by step description of how to solve a problem

# Computer Programs

---

- A computer program tells a computer the sequence of steps needed to complete a specific task
  - The program consists of a very large number of primitive (simple) instructions
- Computers can carry out a wide range of tasks because they can execute different programs
  - Each program is designed to direct the computer to work on a specific task

## ***Programming:***

- The act of designing, implementing, and testing computer programs

# Hardware and Software

---

THE BUILDING BLOCKS THAT MAKE UP A  
COMPUTER

# Hardware

---

- **Hardware** consists of the physical elements in a computer system.
  - Some very visible examples are the monitor, the mouse, external storage, and the keyboard.
- The **central processing unit** (CPU) performs program control and data processing
- Storage devices include memory (RAM) and secondary storage
  - Hard disk
  - Flash drives
  - CD/DVD drives
- Input / output devices allow the user to interact with the computer
  - Mouse, keyboard, printer, screen...

# Simple View of a Computer's Components

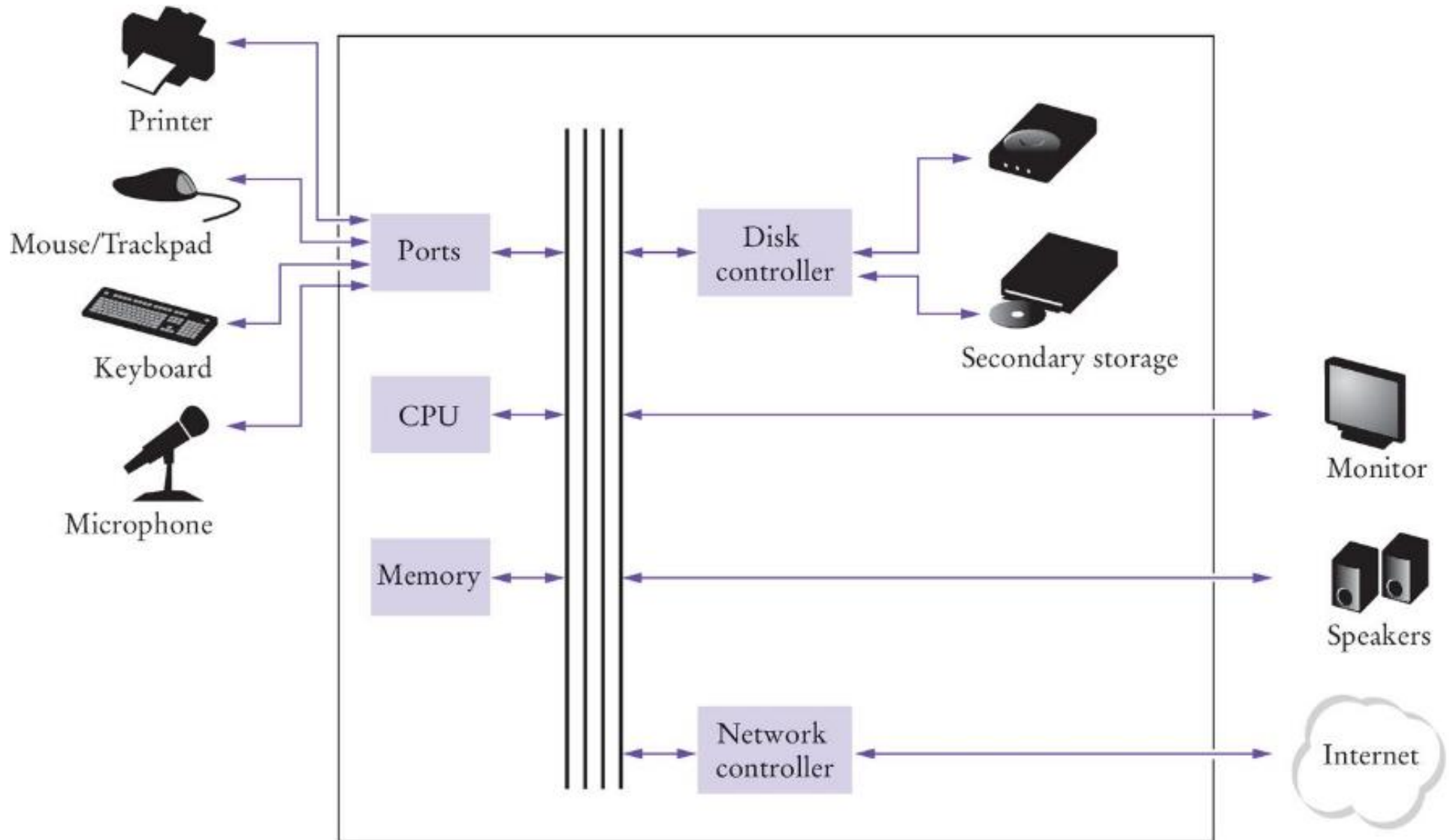

# The CPU

---

- The CPU has two components, the **control unit** and the **arithmetic logic unit**
- The ***control unit*** directs operation of the processor.
  - All computer resources are managed by the **control unit**.
  - It controls communication and co-ordination between input/output devices.
  - It reads and interprets instructions and determines the sequence for processing the data.
  - It provides timing and control signals
- The ***arithmetic logic unit*** contains the circuitry to perform calculations and do comparisons.
  - It is the workhorse portion of the computer and its job is to do precisely what the control unit tells it to do.



# Storage

---

- There are two types of storage:
  - Primary Storage
  - Secondary Storage
- Primary storage is composed of memory chips: electronic circuits that can store data as long as it is provided electric power
- Secondary storage provides a slower, less expensive storage that is persistent: the data persists without electric power
- Computers store both data and programs
  - The data and program are located in secondary storage and loaded into memory when the program is executed

# Memory

---

- A simple way to envision primary memory is a table of cells all the same size, one byte, and each containing a unique address beginning with 0.
  - The “typical” computer has a main memory ranging from 4 gigabytes (GB), to 32 GB.
- How big is a gigabyte?
  - A byte is 8 bits.
  - A kilobyte, KB, is 1024 bytes, or “about 1 thousand bytes.”
  - A megabyte, MB, is 1,048,576 bytes, or “about 1 million bytes.”
  - A ***gigabyte***, GB, is 1,073,741,824 bytes or “about 1 billion bytes.”

# Executing a Program

---

- Program instructions and data (such as text, numbers, audio, or video) are stored in digital format
- When a program is started, it is brought into memory, where the CPU can read it.
- The CPU runs the program one instruction at a time.
  - The program may react to user input.
- The instructions and user input guide the program execution
  - The CPU reads data (including user input), modifies it, and writes it back to memory, the screen, or secondary storage.

# Software

---

- **Software** is typically realized as an application program
  - Microsoft Word is an example of software
  - Computer Games are software
  - Operating systems and device drivers are also software
- Software
  - Software is a sequence of instructions and decisions implemented in some language and translated to a form that can be executed or run on the computer.
- Computers execute very basic instructions in rapid succession
  - The basic instructions can be grouped together to perform complex tasks
- Programming is the act of designing and implementing computer programs

# Introduction to Algorithms

---

- If you want a computer to perform a task, you start by writing an algorithm
- An **Algorithm** is:
  - a sequence (the order mattering) of actions to take to accomplish the given task
  - An algorithm is like a recipe; it is a set of instructions written in a sequence that achieves a goal
- For complex problems software developers write an algorithm before they attempt to write a computer program
- For this class we will ALWAYS write an algorithm for each project
- Developing algorithms is a fundamental problem solving skill
  - It has uses in many fields outside of Computer Science

# Algorithm: Formal Definition

---

An ***algorithm*** describes a sequence of steps that is:

1. Unambiguous
  - a. No “assumptions” are required to execute the algorithm
  - b. The algorithm uses precise instructions
2. Executable
  - a. The algorithm can be carried out in practice
3. Terminating
  - a. The algorithm will eventually come to an end, or halt

# Problem Solving: Algorithm Design

---

- Algorithms are simply plans
  - Detailed plans that describe the steps to solve a specific problem
- You already know quite a few
  - Calculate the area of a circle
  - Find the length of the hypotenuse of a triangle
- Some problems are more complex and require more steps
  - Calculate PI to 100 decimal places
  - Calculate the trajectory of a missile

# A Simple Example

---

- A simple algorithm to get yourself a drink of orange juice
  - For simplicity, the following are true:
    - You have a clean glass in the cabinet
    - You have orange juice in your refrigerator
- So one valid algorithm is:
  1. get a glass from your cabinet
  2. go to the refrigerator and get the orange juice container
  3. open the orange juice container
  4. pour the orange juice from the container into the glass
  5. put the orange juice container back in the refrigerator
  6. drink your juice



# Second Example: Selecting a Car

---

## Problem Statement:

- You have the choice of buying two cars.
- One is more fuel efficient than the other, but also more expensive.
- You know the price and fuel efficiency (in miles per gallon, mpg) of both cars.
- You plan to keep the car for ten years.
- Which car is the better deal?

# Developing the Algorithm

---

Determine the inputs and outputs

From the problem statement we know:

- Car 1: Purchase price, Fuel Efficiency
- Car 2: Purchase price, Fuel Efficiency
- Price per gallon = \$4.00
- Annual miles driven= 15,000
- Length of time = 10 years

For each car we need to calculate:

- Annual fuel consumed for each car
  - Annual fuel cost for each car
  - Operating cost for each car
  - Total cost of each Car
- Then we select the car with the lowest total cost

# Translating the Algorithm to pseudocode

---

- Break down the problem into smaller tasks
  - ‘Calculate total cost’ for each car
  - To calculate the total cost for each year we need to calculate the operating cost
  - The operating cost depends on the annual fuel cost
  - The annual fuel cost is the price per gallon \* the annual fuel consumed
  - The annual fuel consumed is the annual miles drive / fuel efficiency
- Describe each subtask as pseudocode
  - total cost = purchase price + operating cost

# The Pseudocode

---

For each Car, compute the total cost

Annual fuel consumed = annual miles driven / fuel efficiency

Annual fuel cost = price per gallon \* annual fuel consumed

Operating cost = Length of time \* annual fuel cost

Total cost = purchase price + operating cost

If total cost1 < total cost2

Chose Car1

Else

Choose Car2

# Bank Account Example

---

- Problem Statement:
  - You put \$10,000 into a bank account that earns 5 percent interest per year. How many years does it take for the account balance to be double the original?
- How would you solve it?
  - Manual method
    - Make a table
    - Add lines until done
  - Use a spreadsheet!
    - Write a formula
      - Per line, based on line above

year	balance
0	10000
1	$10000.00 \times 1.05 = 10500.00$
2	$10500.00 \times 1.05 = 11025.00$
3	$11025.00 \times 1.05 = 11576.25$
4	$11576.25 \times 1.05 = 12155.06$

# Develop the algorithm steps

- You put \$10,000 into a bank account that earns 5 percent interest per year. How many years does it take for the account balance to be double the original?

- Break it into steps

- Start with a year value of 0 and a balance of \$10,000
- Repeat the following while the balance is less than \$20,000
  - Add 1 to the year value
  - Multiply the balance by 1.05
    - (5% increase)

- Report the final year value as the answer

year	balance
0	10000

year	balance
0	10000
1	10500

14	19799.32
15	20789.28

# Translate to pseudocode

---

- Pseudocode
  - Half-way between natural language and a programming language
- Modified Steps
  - Set the year value of 0
  - Set the balance to \$10,000
  - While the balance is less than \$20,000
    - Add 1 to the year value
    - Multiply the balance by 1.05
  - Report the final year value as the answer
- The pseudocode is easily translated into Python

# The Python Language

---

- In the early 1990' s, Guido van Rossum designed what would become the Python programming language
- Van Rossum was dissatisfied with the languages available
  - They were optimized to write large programs that executed quickly
- He needed a language that could not only be used to create programs quickly but also make them easy to modify
  - It was designed to have a much simpler and cleaner syntax than other popular languages such as Java, C and C++ (making it easier to learn)
  - Python is interpreted, making it easier to develop and test short programs
- Python programs are executed by the Python interpreter
  - The interpreter reads your program and executes it



# Programming Environments

---

- There are several ways of creating a computer program
  - Using an Integrated Development Environment (IDE)
  - Using a text editor
- You should use the method you are most comfortable with
- We will be using **IDLE** in this course
- The Textbook uses the **Wing IDE**

# Organize your work

---

- Your ‘source code’ is stored in .py files
- Create a folder for this course
- Create one folder per program inside the course folder
  - A program can consist of several .py files
- Be sure you know where your IDE stores your files
  - You need to be able to find you files
- Backup your files:
  - To a USB flash drive
  - To a network drive

# Python interactive mode

---

- Like other languages you can write/save a complete Python program in a file and let the interpreter execute the instructions all at once.
- Alternatively you can run instructions one at a time using interactive mode.
  - It allows quick ‘test programs’ to be written.
  - Interactive mode allows you to write python statements directly in the console window

# Source Code to a Running Program

---

- The compiler reads your program and generates byte code instructions (simple instructions for the Python Virtual machine)
  - The Python Virtual machine is a program that is similar to the CPU of your computer
  - Any necessary libraries (e.g. for drawing graphics) are automatically located and included by the virtual machine

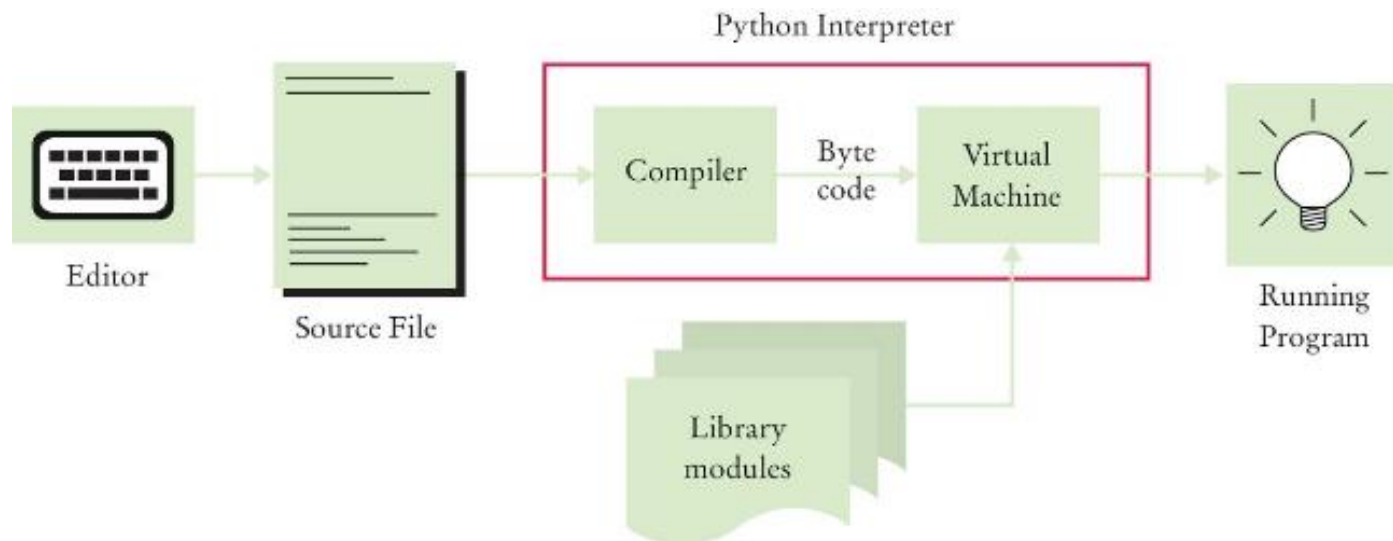

# Basic Python Syntax: *Print*

---

- Using the Python ‘print()’ function.
  - A function is a collection of programming instructions that carry out a particular task (in this case to print a value onscreen).
  - It’s code that somebody else wrote for you!

*Syntax*    `print()`  
`print(value1, value2, ..., valuen)`

All arguments are optional. If no arguments are given, a blank line is printed.

```
print("The answer is", 6 + 7, "!")
```

The values to be printed, one after the other, separated by a blank space.

# Syntax for Python Functions

---

- To use, or call, a function in Python you need to specify:
  - The name of the function that you want to use (in the previous example the name was print)
  - Any values (arguments) needed by the function to carry out its task (in this case, “Hello World!”).
  - Arguments are enclosed in parentheses and multiple arguments are separated with commas.
  - A sequence of characters enclosed in quotations marks are called a string

# More Examples of the print Function

---

- Printing numerical values
  - `print(3 + 4)`
  - Evaluates the expression `3 + 4` and displays `7`
- Passing multiple values to the function
  - `print("the answer is", 6 * 7)`
  - Displays The answer is 42
  - Each value passed to the function is displayed, one after another, with a blank space after each value
- By default the print function starts a new line after its arguments are printed
  - `print("Hello")`
  - `print("World!")`
  - Prints two lines of text
  - Hello
  - World!

# Errors

---

- There are two Categories of Errors:
  - Compile-time Errors
    - aka Syntax Errors
      - Spelling, capitalization, punctuation
      - Ordering of statements, matching of parenthesis, quotes...
    - No executable program is created by the compiler
    - Correct first error listed, then compile again.
      - Repeat until all errors are fixed
  - Run-time Errors
    - aka Logic Errors
    - The program runs, but produces unintended results
    - The program may 'crash'



# Syntax Errors

---

- Syntax errors are caught by the compiler
- What happens if you
  - Miss-capitalize a word: `Print("Hello World!")`
  - Leave out quotes `print>Hello World!`
  - Mismatch quotes `print("Hello World!')`
  - Don't match brackets `print('Hello'`
- Type each example above in the Wing **Python Shell** window
  - What error messages are generated?

# Logic Errors

---

- What happens if you
  - Divide by zero `print(1/0)`
  - Misspell output `print("Hello, Word!")`
  - Forget to output Remove line 2
- Programs will compile and run
  - The output may not be as expected
- Type each example above in the **Python Shell** window
  - What error messages are generated?

# Summary: Computer Basics

---

- Computers rapidly execute very simple instructions
- *A Program* is a sequence of instructions and decisions
- *Programming* is the art (and science) of designing, implementing, and testing computer programs
- The Central Processing Unit (CPU) performs program control and data processing
- Storage devices include memory and secondary storage (e.g., a USB Flash Drive)

# Summary: Python

---

- Python was designed in a way that makes it easier to learn than other programming languages such as Java, C and C++.
- The designers goal was to give Python simpler and cleaner syntax.
- Set aside some time to become familiar with the programming environment that you will use for your class work.
  - It is important to practice with the tool so you can focus on learning Python
- An editor is a program for entering and modifying text, such as a Python program.

# Summary: Python

---

- Python is case sensitive.
  - You must be careful about distinguishing between upper and lowercase letters.
- The Python compiler translates source code into byte code instructions that are executed by the Virtual machine.
- A function is called by specifying the function's name and its parameters.
- A string is a sequence of characters enclosed in quotation marks.

# Summary: Errors and pseudo code

---

- A compile-time error is a violation of the programming language rules that is detected by the compiler.
- A run-time error causes a program to take an action that the programmer did not intend.
- Pseudo code is an informal description of a sequence of steps for solving a problem.
- An algorithm for solving a problem is a sequence of steps that is unambiguous, executable, and terminating.